



SINGLE STOCK POTS



Stratus Stock Pot provides standard, many of the optional upgrades normally offered at a premium on other Stock Pot lines. Constructed for durability they are made of heavy gage steel with a sturdy chassis design. The three ring burner provides high performance cooking in a wide variety of applications.

For quick clean ups, a full width removable drip tray is standard. The top grate has a gradual slope to reduce spill over and will accommodate any size pot.

- Standard Features:**
- Stainless steel front and sides.
 - Heavy duty cast iron top grates are easily removable for cleaning. Inner bowl slope design reduces spill over.
 - Three ring burner with two adjustable gas valves that provides flexibility and 90,000 BTU/hr high performance cooking.
 - Burners are equipped with two continuous pilots for instant ignition.
 - Sturdy stainless cabinet base provides additional storage.
 - Chrome plated 6" legs with adjustable feet are standard.

Model	SSP-18-18H.
Number of Burners	1
BTU's	90,000
Dimensions (WxDxH*)	18"x21"x18"
Weight	135 lbs.

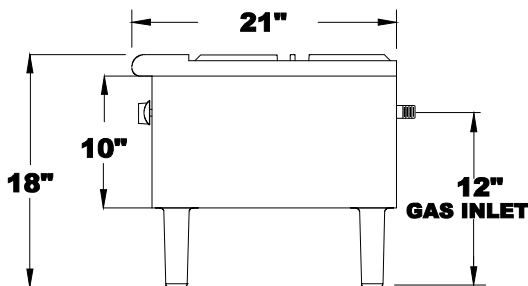

Model	SSP-18-24H.
Number of Burners	1
BTU's	90,000
Dimensions (WxDxH*)	18"x11"x24"
Weight	150 lbs

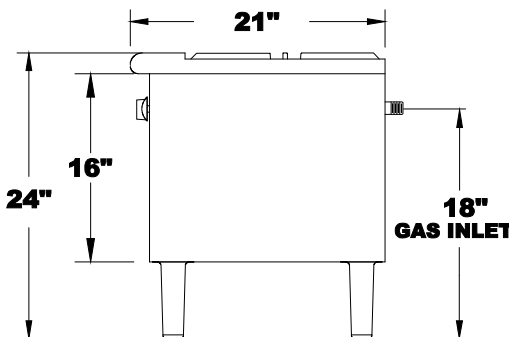

Clearances:

	Combustable	Non combustable
Rear	N/A	15"
Sides	N/A	15"

Gas Pressure.	
5" W.C	Natural Gas
10" W.C	LP Gas



STRATUS EQUIPMENT INCORPORATED.
1760 West First st. Azusa CA 91702 Phone 626-969-7041 Fax 626-969-7078
www.stratusequipment.com
stratusequipment@yahoo.com